

# 209F Flanged Ball Valve

2-Piece Full Port (ANSI 150/300)  
ISO 5211 Direct Mount Pad



For Automated &  
Manual Service

---

General Chemical

---

Industrial

---

and Other Corrosion  
Resistant Applications

---

# The 209F Series Ball Valve

The 209F series ball valve has a true full port design and is available with 150# or 300# flanged ends. The new, dual pattern ISO 5211 mounting pad facilitates mounting of pneumatic and electric actuators.

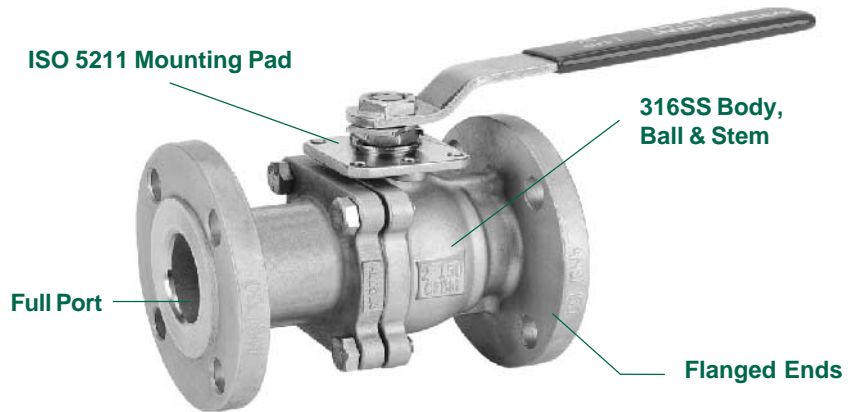

## Standard Features and Benefits

- 1 **Full Port Design**  
Full port construction improves flow characteristics for greater process efficiencies
- 1 **High-Cycle, Live-Loaded Stem Packing (1/2" - 4")**  
Ensures tight seal  
Extends service life
- 1 **Adjustable Packing Gland (6" - 12")**
- 1 **Blow-Out-Proof Stem**  
Stem is bottom loaded to prevent removal when valve is in service
- 1 **Locking Device**  
Enables plant personnel to secure valve in open or closed position when manually operated
- 1 **ISO 5211 Mounting Pad**
- 1 **Anti-static device**
- 1 **Investment Cast (1/2" - 4")**  
Improves dimensional control and reduces porosity
- 1 **Sand Cast with Hollow Ball (6" - 12")**

## Options

- 1 **Carbon Steel construction to NACE MR01.75**
- 1 **Oval Handle (1/2" - 1-1/2")**

209F Pressure / Temperature Chart  
(RTFE Seats)

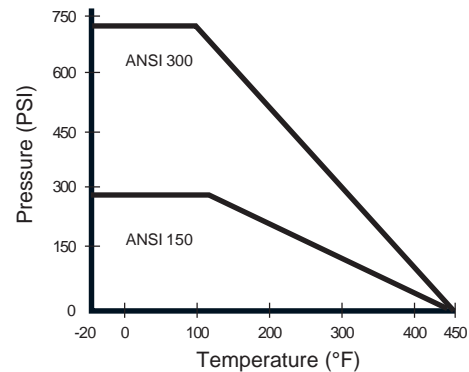

## Operating Conditions

- 1 Temperature range (RTFE):  
-20°F ~ 450°F
- 1 Maximum pressure (RTFE):  
ANSI 150: 275 PSI WOG @ 100°F  
ANSI 300: 720 PSI WOG @ 100°F

## Specifications

- 1 All valves shell and seat tested to ANSI/ASME B16.34 and API 598
- 1 Length to ANSI B16.10,  
Connection to ANSI B16.5

### 1/2" - 4"

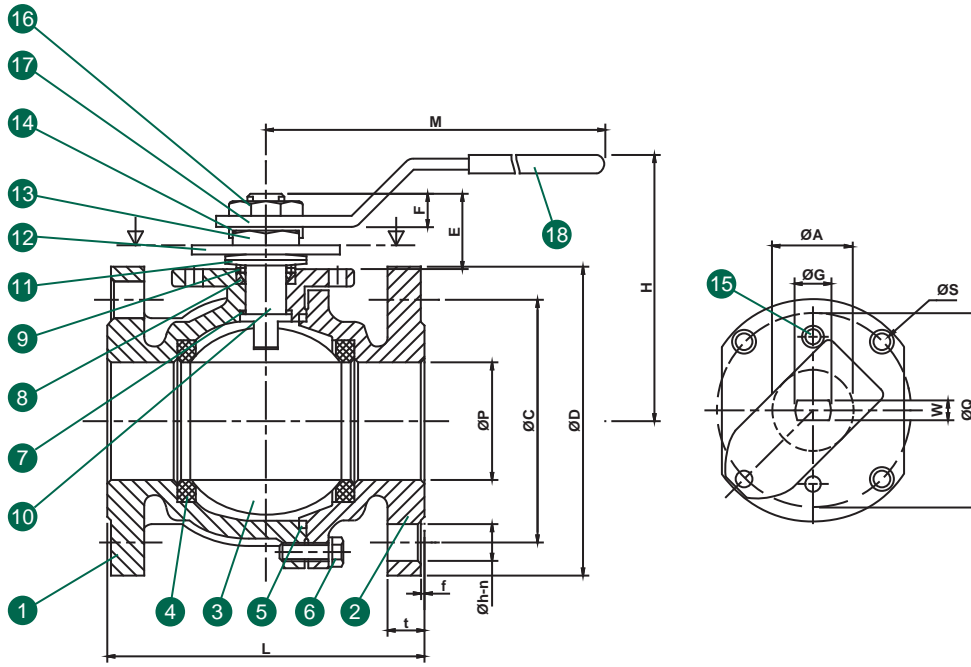

Valve Components			
#	Part Name	Material	Qty.
1	Body	A351 Gr. CF8M	1
2	End Cap	A351 Gr. CF8M	1
3	Ball	316SS	1
4	Seat	RTFE (15% C.F.)	2
5	Body Seal	PTFE	1
6	Bolt & Washer	304SS	n*
7	Thrust Washer	PEEK	1
8	Stem Packing Set	PTFE	1
9	Packing Gland	304SS	1
10	Stem	316SS	1
11	Belleville Washer	301SS	2
12	Stop Plate	304SS	1
13	Gland Nut	304SS	1
14	Gland Nut Lock Washer	304SS	1
15	Positioning Pin	304SS	1
16	Handle Nut	304SS	1
17	Handle	304SS	1
18	Handle Cover	Vinyl	1

\* See dimension table below

### 6" - 12"

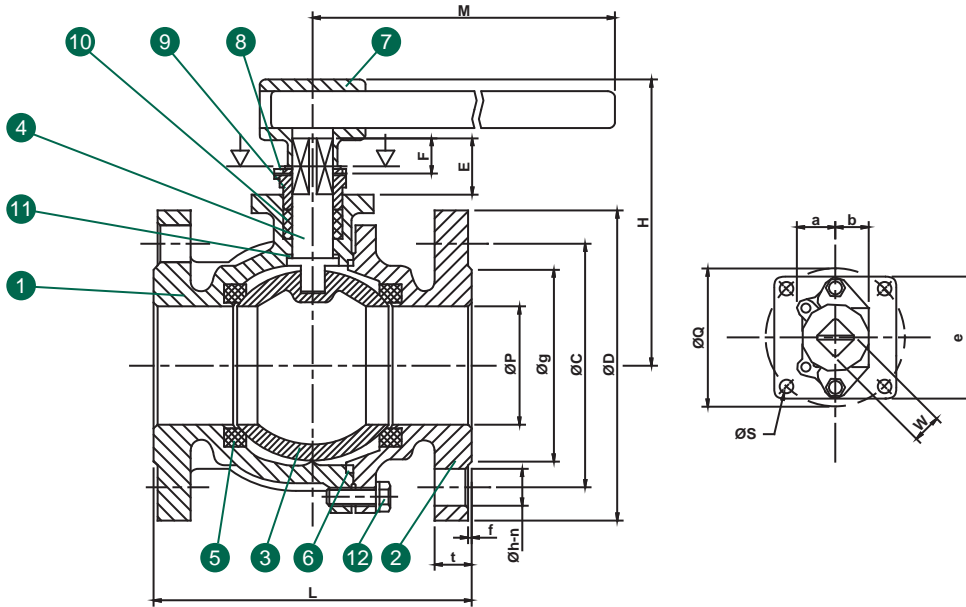

Valve Components			
#	Part Name	Material	Qty.
1	Body	A351 Gr. CF8M	1
2	End Cap	A351 Gr. CF8M	1
3	Ball	316SS	1
4	Stem	316SS	1
5	Seat	RTFE (15% C.F.)	2
6	Body Seal	PTFE	1
7	Handle	Ductile (Steel Pipe)	1
8	Stop Plate	304SS	1
9	Gland	304SS	1
10	Stem Packing Set	PTFE	1
11	Thrust Washer	PEEK	1
12	Bolt & Washer	304SS	n*

\* See dimension table below

Dimensions (Inches)																														
Size	ØA	F	ØP	H	M	E	W	ØQ	ØS	ØG	a	b	e	Øg	f	L		End Flange (ANSI 150)				End Flange (ANSI 300)				Wt. (lbs)		CV		
																ANSI 150	ANSI 300	ØD	Bolt Hole		t	ØD	Bolt Hole		t	ANSI 150	ANSI 300			
																			ØC	n			Øh	ØC					n	Øh
1/2	1.00	0.32	0.59	2.56	5.51	0.64	0.26	1.65	M5	0.39	-	-	-	0.06	4.25	5.51	3.50	2.38	4	0.63	0.44	3.74	2.62	4	0.56	0.56	4.40	5.80	29	
3/4	1.00	0.32	0.79	2.95	5.51	0.64	0.26	1.65	M5	0.39	-	-	-	0.06	4.61	5.98	3.96	2.76	4	0.63	0.44	4.61	3.25	4	0.63	0.63	5.50	8.10	54	
1	1.15	0.43	0.98	3.34	6.69	0.79	0.38	1.96	M6	0.55	-	-	-	0.06	5.00	6.50	4.25	3.13	4	0.63	0.44	4.88	3.50	4	0.70	0.70	6.60	10.0	89	
1 1/2	1.60	0.59	1.57	4.13	9.06	1.28	0.38	2.76	M8	0.71	-	-	-	0.06	6.50	7.48	5.00	3.88	4	0.63	0.62	6.14	4.51	4	0.81	0.81	13.4	19.7	219	
2	1.60	0.59	1.97	4.53	9.06	1.28	0.38	2.76	M8	0.71	-	-	-	0.06	7.01	8.50	5.98	4.74	4	0.75	0.76	6.50	5.50	8	0.88	0.88	16.8	22.3	397	
2 1/2	1.75	0.77	2.56	5.20	13.78	1.35	0.47	4.02	M10	0.79	-	-	-	0.06	7.48	9.49	7.01	5.49	4	0.75	0.88	7.48	5.87	8	1.00	1.00	30.8	42.5	689	
3	1.75	0.77	3.15	5.75	13.78	1.35	0.47	4.02	M10	0.79	-	-	-	0.06	7.99	11.14	7.48	6.00	4	0.75	0.94	8.63	6.61	8	1.13	1.13	35.4	54.9	1020	
4	1.90	0.91	3.94	6.50	13.78	1.80	0.59	4.02	M10	0.94	-	-	-	0.06	9.02	12.00	9.02	7.50	8	0.75	0.94	10.00	7.87	8	1.25	1.25	55.0	81.2	1680	
6	-	1.67	5.95	10.04	32.28	2.46	1.10	4.92	M12	-	1.42	1.20	4.50	8.50	0.06	15.51	16.00	10.98	9.51	8	0.87	1.00	12.52	10.63	12	0.87	1.46	118.0	168.0	5000
8	-	1.69	7.90	13.39	41.34	2.56	1.41	4.92	M12	-	1.71	1.40	5.35	10.63	0.06	17.99	20.00	13.50	11.75	8	0.87	1.13	15.00	13.00	12	1.00	1.63	202.0	304.0	9800
10	-	1.83	9.90	14.96	41.34	2.60	1.41	4.92	M12	-	1.71	1.40	5.35	12.76	0.06	20.98	22.50	15.98	14.25	12	0.98	1.19	17.52	15.25	16	1.12	1.89	326.0	476.0	15200
12	-	1.61	11.85	22.36	57.48	2.91	1.41	5.51	M16	-	1.71	1.50	5.50	15.00	0.06	24.01	-	19.02	17.01	12	0.98	1.25	20.47	17.75	16	1.25	2.01	-	-	21200

\*\* Torque data available upon request.



Automation Systems



Direct Mount Products

## 209F Ordering Information

Example: 2" 209F Full Port Ball Valve, with ISO 5211 Actuator Mounting Pad and Locking Device, 316SS Body and Trim, RTFE (15% C.F.) Seats, PTFE Seals, ANSI 150# Flanged Ends

**209F**   **D**   **6**   **6**   **6**   **6**   **C**   **T**   **AA**   **2**   **S**

Valve Series	Valve Size	Body Material	End Material	Ball Material	Stem Material	Seat	Seal	End Connection	Port Config.	Ball Config.
209F - Full Port	5	1/2"	6 - A351 Gr.	6 - A351 Gr.	6 - A351 Gr.	<b>C</b> - RTFE (15% C.F.) <b>F</b> - 50% 316SS Filled PTFE <b>T</b> - PTFE <b>U</b> - UHMWPE	<b>T</b> - PTFE <b>U</b> - UHMWPE <b>F</b> - 50% 316SS Filled PTFE	<b>A</b> - ANSI 150# Flanged <b>B</b> - ANSI 300# Flanged	<b>2</b> - 2 Way	<b>S</b> - Straight Port
	7	3/4"	CF8M (316)	CF8M (316)	CF8M (316)					
	A	1"	2 - A216 Gr.	2 - A216 Gr.						
	C	1 1/2"	WCB	WCB						
	D	2"								
	E	2 1/2"								
	F	3"								
	G	4"								
	I	6"								
	J	8"								
	K	10"								
	L	12"								

Due to continuous product development, information may change without notice.



Distributed by:

### INLINE INDUSTRIES, INC.

4701-A Littlejohn Street  
 Baldwin Park, CA 91706  
 Tel: (626) 813-6188  
 Fax: (626) 813-6186  
[www.ballvalve.com](http://www.ballvalve.com)  
[info@ballvalve.com](mailto:info@ballvalve.com)